

CFA Guidance Note: Resin Bonded Anchors

1 INTRODUCTION

This Guidance Note supersedes that published in December 1994 entitled "Introduction to Bonded Anchors" since which time the introduction of new formats and formulations, warrants an update. Cementitious bonding materials are no longer covered.

2 SUMMARY

- ❑ *New developments give improved problem solving.*
- ❑ *Additional capabilities mean systems may be matched to application requirements.*
- ❑ *Different installation parameters mean installers must always work to manufacturers instructions.*
- ❑ *Certified Load data from fire tests mean anchors may be specified for fire rated applications.*

3 VERSATILE PROBLEM SOLVERS

Strength and versatility

Bonded anchors have earned an enviable reputation as problem solvers by virtue of their unique combination of strength and versatility. Usually the resin bond is stronger than the base material and ultimate strength is governed by anchor rod specification. They offer stress free anchorages which will not damage weak substrates and can be placed closer to edges and to each other than other techniques. Resin anchors cope with base materials as diverse as concrete and hollow block, rock and aerated concrete, stone and perforated brick. By filling the hole with material they help protect the anchor rod from corrosion and the base material from water ingress. They resist vibration.

Wide ranging applications

Bonded anchors cover as wide a range of applications as any fixing technique available, they include:

Structural connections transferring high loads into slim columns and beams; fixing sanitary ware to hollow masonry; holding down bolts for steel columns; tying back existing masonry to steel structures. Dynamic applications include holding down machinery such as fans and motors and withstanding the shock loads of fall arrest systems.

The ability to anchor irregular shapes lends itself to grouting in starter bars and architectural features such as balustrade sections.

Special systems are available for holding down motorway safety fences, remedial wall ties, safety harness eyebolts, ladder restraint systems and many more.

Mining and tunnelling engineers use resin anchor systems which can be set deep into rocks for roof stabilisation.

With care most systems can be installed overhead and some can be installed underwater while many are suitable for installation and use in permanently damp applications. Formulations are available which offer fast or slow curing rates for a variety of uses including winter or summer use.

4 NEW DEVELOPMENTS

The category "Bonded anchors" has seen the most rapid development of all fixing types over recent years with new product concepts, new formulations and the prospect of products gaining European Technical Approvals (See CFA Guidance Note^[1]) to a new Guideline^[2].

New products are continuously being developed. They may have different application limits, different performance and different installation requirements compared with existing types even with similar configurations or resin names. It is therefore vital that bonded anchors are specified and installed strictly according to the particular manufacturer's data. Specifications should not be changed without a thorough check that all parameters are equivalent.

For safety critical applications manufacturers will provide technical support to ensure the most appropriate system is chosen, training for installers to ensure it is correctly installed and on site testing to validate performance.

New formulations

The additional capabilities of formulations recently introduced, include the ability to work at higher ambient temperatures, use in permanently wet applications, setting under water, low shrink characteristics for use in large diameter holes, solvent free formulations and high flash point formulations to reduce flammability. Particular characteristics vary with formulation.

New configurations

Most significant among new configurations are "Torque controlled" capsule anchors and "Hammer-in" capsule anchors. These are described in more detail in section 7.

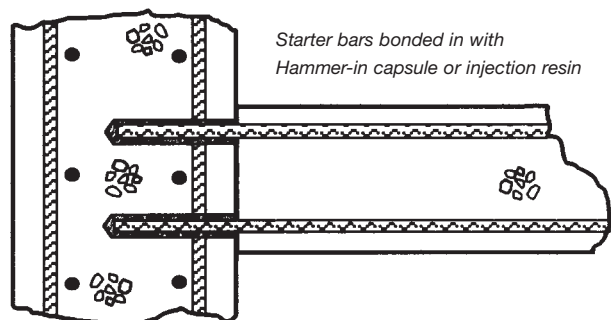

5 FIXINGS AND FIRE

All anchors, either resin or all-steel, will eventually lose strength with prolonged exposure to fire, failure often occurring at the bolt head or nut. The durability of resin anchors in fire tests has been shown to be comparable with that of all-steel anchors. A CFA Guidance Note^[3] elaborates three methods by which anchors, including resin anchors, may be specified for fire rated applications.

6 EUROPEAN TECHNICAL APPROVALS

Manufacturers are now able to apply for approvals of bonded anchors in accordance with the requirements of ETAG 001^[2] Part 5 Bonded anchors.

Bonded anchors with ETAs will have been subjected to the most rigorous test regime ever applied to an anchoring product. This means specifiers can have full confidence in specifying bonded anchors with ETAs.

CFA Guidance Note: Resin Bonded Anchors

7 RESIN ANCHOR FORMATS

7.1 CAPSULE SYSTEMS

Capsule systems have the benefit of delivering the correct amount of all components in the right proportions into the hole and so lend themselves to use in homogeneous materials without voids i.e. solid concrete and solid masonry.

“SPIN-IN” CAPSULE ANCHORS

The term “Spin-in” has been adopted only for this Guidance Note to differentiate this type from the “Hammer-in” type. “Spin-in” formats include GLASS, FOIL and SOFT SKIN.

Glass Capsules

The original glass capsule format. A glass capsule contains the resin, a quartz sand aggregate and a catalyst, usually in a small secondary phial. A special anchor rod with a chamfered end is driven into the capsule using a drilling machine on *rotary hammer* to mix the components. The relatively large size of the aggregate (compared to injection systems) endows the cured resin with high strength (although some new injection systems are as strong as capsule anchors). The smashed glass becomes part of the aggregate.

Foil Capsules

A new development using foil to contain the components. Applications and installation are similar to glass capsules, but, like soft skin capsules they are less prone to damage.

Soft Skin Capsules

Soft skin resin anchors have been in use for almost as long as glass capsules. Their installation is similar in that a special anchor rod is spun into the capsule using a drilling machine but can be set on *rotary* only. The construction of Soft Skin capsules means shelf life is less than for Glass and Foil capsules. Different curing rates are available for different temperature conditions and applications. These systems are often used for mining and tunnelling as they lend themselves to overhead use. As it is possible to spin the anchor rod into deep holes using more than one capsule it is possible to pre-tension the anchor by using capsules of different curing rates. A fast cure capsule is set at the remote end with slow cure capsules nearer the surface.

“HAMMER-IN” CAPSULE ANCHORS

Originally developed to provide a quick installation solution for starter bars by hammering deformed bar directly into special resin capsules they are now also offered by some manufacturers for use with threaded anchor rods. A special glass capsule is inserted into the hole and the deformed bar or threaded rod is then hammered directly into the capsule drawing the catalyst through the resin. Some hammer-in capsule are directional, i.e. the catalyst is only at one end of the capsule which must be placed toward the outer end of the hole. The capsule has an arrow indicating which way the capsule should be inserted. With this type inserting the capsule the wrong way round will result in zero holding power. Special hammering adaptors are available for use with rotary hammer drilling machines to set both rebar or threaded anchor rods and while rebars may also be set using a

conventional hammer of suitable weight, this technique should not be applied to threaded rods unless threads are protected. Hole diameters are different for rebar and threaded rod.

The glass capsule of this type is similar in appearance to that of the “Spin-in” variety which does not work if simply hammered home so care must be taken not to confuse the two and installation instructions must be clearly communicated to the installer.

“TORQUE CONTROLLED” CAPSULE ANCHORS

Developed to work in cracked concrete, and to pass the strict requirements for European Technical Approvals these anchors use specially developed anchor rods set in special glass or foil capsules. They must be tightened to the manufacturer’s recommended tightening torque to make them work in cracks. They offer benefits over torque controlled metal anchors in terms of close edge and spacing criteria but the stresses induced in the concrete means that edge and spacing criteria may be poorer than ordinary capsule anchors when set in un-cracked concrete.



Example of torque controlled anchor rod, tapered cones transfer loads through resin in cracked concrete.

7.2 INJECTION CARTRIDGE SYSTEMS

The versatility of this technique has prompted dramatic growth in use in recent years. Resin components are carried in separate compartments of a cartridge held in a special skeleton gun. They are mixed by a series of vanes in a special



Typical injection cartridge and static mixer nozzle

nozzle as they are expelled from the cartridge. Unused resin can be kept without deterioration (subject to shelf life). Waste is restricted to that contained in the nozzle. The amount of resin used can be tailored to the application which is ideal for use in materials containing voids such as light weight aggregate blockwork. Special mesh sleeves facilitate use in hollow blocks and perforated bricks. With each fresh cartridge some resin must be expelled to waste, until an even colour is achieved demonstrating that proper mixing is taking place.

7.3 FREE MIX SYSTEMS

Resin components are packaged separately and mixed by the installer in a container. The mixed resin is then placed into the hole either by pouring, if the hole is vertically down, or via a cartridge for horizontal holes. Once mixed the resin has a limited “Open time” during which it must be placed and the anchor rod inserted. This means preparing all holes before mixing. Components must be mixed in the correct proportions to achieve quoted performance. Ideally mix full amounts as supplied. (ETAs will only be awarded for Free Mix systems used in this manner.) If components are to be mixed in smaller amounts care should be taken to ensure accurate proportioning. Special mixing paddles are available for mixing large volumes.

7.4 ACCESSORIES

For general purpose anchoring bonded anchors are used with fully threaded anchor rods or rods made from deformed bar with a threaded end to accept a nut.

Internally threaded sockets can be used with most systems to accept hexagon headed bolts.

Other special types of anchorage include block end bolts for particularly high loadings where de-bonding of the anchor rod from the resin along with the block-end means load transfer is effected deep into the structure.

Mesh sleeves, of plastic or steel, are available for use particularly with injection and free mix systems, to control resin in hollow, perforated or voided materials.

Mesh and perforated sleeves



Plastic for perforated brickwork..... and hollow blocks



Steel - for long studs in poor masonry

Internally threaded sockets



Special, for shallow embedment, with anti-rotation fins and tapered ridges for pullout resistance

End cones



For injection overhead

Cavity fixings



For hollow and thin materials

To ensure the manufacturer's performance is achieved only anchor rods supplied by the manufacturer, or made to the manufacturer's specification in terms of both form, e.g. chisel point, and material specification, should be used.

8 RESIN FORMULATIONS

A wide variety of different resin formulations is now available and while all will satisfy general purpose requirements some offer additional benefits. Typical parameters which differentiate each resin type are outlined below but individual formulations vary so specifiers are advised to check that the characteristics offered by a particular formulation suit the requirements of the application concerned.

8.1 RESIN FAMILIES

There are two basic families, those cured by a catalytic action and those cured by direct mixing of the components.

CATALYTIC CURING.

A catalyst initiates the curing of the resin itself. Exact mix proportions of catalyst and resin are not critical nor does the catalyst have to be mixed with all of the resin, the reaction will propagate through the mix as long as most of the base resin is exposed to some catalyst. This happens automatically with capsule and injection systems. Most resins for anchoring fall into this category. They have names like Polyester, Vinylester (epoxy acrylate) Vinylesterurethanes, Methacrylates and others. There is little point in trying to categorise them as characteristics and performance vary within these types from one make to another depending on formulation.

Installation parameters also vary even for the same nominal type of resin. Specifiers should choose the best type for the application according to the performance and characteristics of the system under consideration. Styrene free formulations are available which may offer benefits where anchors are to be set in confined spaces. Styrene, as used in many types of resin, has no harmful effects in normal use.

NON-CATALYTIC CURING. In this type the two resin components will cure only in direct contact with each other. Curing does not spread through the resin as with catalytic resins so mixing must be thorough and proportions correct. Injection systems, where component proportions are controlled and mixing takes place in a static mixer nozzle, overcome these problems and guarantee thorough mixing. Resins in free mix format *must* be completely mixed.

Epoxy resin (not to be confused with "Epoxy acrylate") is the only non-catalytic resin currently available, it is usually supplied as an injection system (available from some manufacturers in free mix format). Epoxy resin exhibits very low shrinkage so it may be used in larger holes where the increased surface area may be used to increase load capacity without increasing hole depth. Hole diameters may be increased only within limits recommended by the manufacturer. (Shrinkage of other resin systems is insignificant when used in the narrow gaps implicit in recommended hole diameters.)

APPLICATION PARAMETERS

Installation. Some materials may be installed at temperatures as low as -5°C others, including true Epoxy, may only be installed above +4°C. Resin materials may be warmed – follow the manufacturer's instructions. Most resins may be installed in damp holes, e.g. holes cleaned by thorough flushing with clean water, and some may be installed underwater if the correct procedure is followed.

Service. Most formulations are suitable for short term temperatures up to 80°, some even higher. Long term temperature limits are lower than the maximum short term. Some resins may be used in saturated substrates.

9 HEALTH AND SAFETY

All proprietary resin systems may be specified and installed with complete confidence for the safety of the installer and building users as long as the simple precautions made clear with all products are followed.

10 SPECIFIER'S CHECK LIST

In addition to loading criteria and other selection criteria (see [4]) check the resin characteristics against service and installation requirements for the following:

- Base material solid, perforated or hollow.
- Service temperatures.
- Service condition of base materials e.g. permanently damp.
- Installation conditions e.g. wet holes.

Specify the following:

- Resin material, embedded part (anchor rod/socket etc) including finish.
- Special components for perforated or hollow materials or for over head installation (injection systems).
- Precise installation method including equipment.
- Installation temperature range and curing times.
- Tightening torque to suit base material.

IF IN DOUBT CONSULT THE MANUFACTURER

CFA Guidance Note: Resin Bonded Anchors

11 INSTALLATION PROCEDURES

ASPECTS COMMON TO ALL TYPES

Installation principles follow those shown in the CFA Guidance Note on the subject^[5].

Before installation:

READ AND FOLLOW THE INSTRUCTIONS!

Check use by date of resin materials

Check ambient temperature against limits for material

Check temperature of bonding material, raise if necessary as manufacturer's instructions.

Check availability of necessary equipment

Wear protective equipment as necessary:

Eye protection when drilling

Ear protection when drilling in confined spaces

Eye protection when setting resins overhead

Gloves when handling glass capsules or resin

Installation

1 Drill hole to correct diameter and depth

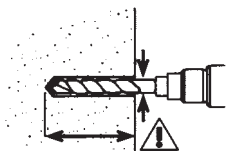

2 Clean hole thoroughly

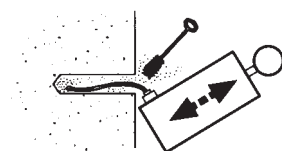

3 Insert mesh sieves or perforated sleeves for hollow or porous materials

4 (Mix and) place resin to manufacturer's instructions

5 Insert anchor rod using correct setting equipment

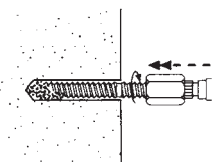

6 Allow curing times (dependent on temperature)

Before loading and tightening

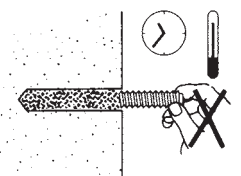

7 Tighten to manufacturer's recommended torque

Reduce in weak materials

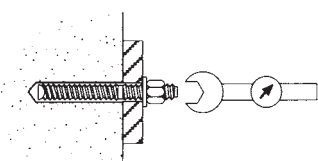

KEY ASPECTS

Hole drilling dimensions

Hole dimensions. These must be maintained as specified.
Hitting rebar. Do not cut the anchor rod. Reposition the anchor or drill through the bar with permission. See [5].

Hole cleaning

All anchors, including all types of metal anchors, benefit from thorough hole cleaning. Spin-in capsule anchors are less sensitive to poor hole cleaning than injection, free mix and hammer-in capsule types as the spinning action draws dust from the hole sides into the mix.

Preferred technique is Blowing (to remove bulk) and Brushing (to remove dust from hole sides). Use large volume air pumps for holes up to 28mm diameter and 330mm deep. For larger holes use an air line or vacuum reaching to the base of the hole. Brushes should be round, and appropriate to hole diameter.

Mixing resin

Free mix systems. Mix in correct proportions and mix thoroughly, both are especially important for Epoxy resins.

Placing resin

Injection systems. Pump to waste until even colour. Inject to base of hole drawing nozzle back to fill without voids. Use cone systems to retain resin when placing overhead.
Hammer-in capsules. Insert in direction of arrow - VITAL.

Inserting the anchor rod

Injection and Free mix. Insert rod with twisting action.

Hammer-in capsule. Use drilling machine with adaptors where possible. If hammering threaded rods protect the thread.

Open and Curing times

Both are temperature dependent. "Open time" (an ETAG term), sometimes referred to as Gel time, is the time after mixing during which the anchor rod must be inserted. The anchor must not be disturbed during the curing time. Times may differ for loading, tightening and testing.

Tightening to recommended torques

This ensures the fixture is clamped by inducing a tension greater than the recommended tensile load. It protects the anchor rod and resin bond from being over stressed.

Torque should be reduced in weak materials to protect the bond -refer to manufacturer for advice.

References:

- [1] CFA Guidance Note: European Technical Approvals for Construction Fixings
- [2] Guideline for European Technical Approval of Metal Anchors for use in Concrete. British Board of Agrément, PO Box 195 Bucknalls Lane, Garston, Watford, WD2 7NG.
- [3] CFA Guidance Note: Fixings and Fire.
- [4] CFA Guidance Note: Anchor selection.
- [5] CFA Guidance Note: Anchor installation.

This is one of a free series of Guidance Notes published by the **Construction Fixings Association**
For more information contact: The Secretary
Construction Fixings Association
C/O Institute of Spring Technology
Henry Street
Sheffield
S3 7EQ
e-mail: info@fixingscfa.co.uk
Tel 0114 2789143
Fax 0114 2755573